

Testing:

Once connected to the 240V mains supply, the unit must be allowed to charge the battery for at least 24 hours. Conduct the following tests:

- For the first test, the emergency lamp must remain illuminated for at least 2 hours (4hrs for -4HR fittings) after disconnection from the mains supply.
- Subsequent tests require the unit to illuminate for at least 90 minutes. The results of all tests are required to be recorded in a service logbook, which is to be kept on-site at all times. If the unit fails to remain illuminated for the requisite time, remedial action must be taken to repair the situation and once completed, the unit must pass a subsequent test. For more specific information, please refer to the current edition of the AS/NZS 2293.2 and AS/NZS 60598.2.22 Standards.
- Press and hold Test Button, the product will go into Dynamic Red mode for the initial 60 seconds of the test button being pressed and then switch to Dynamic Green.

NOTE: Initiating a Function or Duration test using the Zoneworks Software will trigger the Dynamic Red Mode for 60 seconds then Dynamic Green for completion of the test.

Networking:

When installing the product on a monitored network, (ZONENETWORKS, HIVE, DATA, DALI) simply insert the relevant Smart Node PCA.

Trouble Shooting:

Below are a list of common problems and their possible causes.

Fault: The Green LED Test Switch indicator is not illuminated.

Check: A.C. is connected and is turned on.
Battery is connected
Test Switch for damage.

Fault: Lamp does not illuminate in emergency mode.

Check: A.C. is connected.
Lamp is correctly inserted.
Battery is connected

Fault: Lamp illuminates in emergency mode, but only stays on for a short period.

Check: Battery has been allowed to charge for at least 24 hours.
Battery for damage.

Fault: The Dynamic Green is not sequencing.

Check: The 24 Volt/VF control is connected and turned on.
Polarity of 24V control.
Check that the correct interface control is selected.

Fault: The Dynamic Red is not illuminated.

Check: The 24 Volt/VF control is connected and turned on.
Polarity of 24V control.
Check that the correct interface control is selected.
Check that the Dynamic Red is activated on the dip switches.

Rated Emergency Lumen Output in accordance with AS2293.1 (refer to spacing tables for installation positions):

Please refer to the technical label on the product for classification.

Warranty:

For Product Warranty information and Terms and Conditions of Sales please refer to our website <http://clevertronics.com.au/terms-conditions-sale-australia-nz>



L10™ UltraBlade Pro Dynamic Red

Installation & Maintenance Instruction Leaflet



Victoria (Head Office & Manufacturing)
Website: www.clevertronics.com.au
Email: info@clevertronics.com.au
Phone: +61 3 9559 2700
Fax: +61 3 9559 2799

New South Wales
Phone: +61 2 8805 6400
Fax: +61 2 8805 6444

Queensland
Phone: +61 7 3442 9700
Fax: +61 7 3442 9777

South Australia/Northern Territory
Phone: +61 8 8301 8800
Fax: +61 8 8351 8286

Western Australia
Phone: +61 8 9207 0000
Fax: +61 8 9207 0088

New Zealand
Phone: +64 800 548 448

Designed in Australia to comply with the requirements of AS2293.3:2005 (when not activated in the dynamic green or red cross mode) and AS/NZS CISPR22: 2009

Note: AS2293.3 Compliance not applicable to -RU and -RD Products

Models: DYRL-xUP-uu-vv-ww-xx-yy-zz

Testing:

Zoneworks xx = ZW
Z/W DATA xx = DATA
Zoneworks HIVE xx = HV/HVG

Normally Open xx=NO
Normally Closed xx=NC
Activated Only by Fire Panel xx=AOFPP
Weatherproof x=W

Options:

Running man yy=R
Running man with right arrow yy=RR
Running man with left arrow yy=RL
Running man with Up arrow yy=RU
Running man with down arrow yy=RD
Dynamic Green Disabled uu=DDG
Theater Mask vv=TH
SoundEscape module ww=SND
4 Hour run time zz = 4HR

Spare Parts:

1530050 Replacement Battery (Extra for -4HR)
1530250 Replacement Battery
AUM01570070001 Replacement Emergency Driver
AUM01970160001 Replacement Emergency Driver (-HVG)

Important:

It is illegal for anyone, except for a licensed electrician to install or maintain this product. Before installation, ensure that the electricity supply has been switched off and isolated. Installation must be carried out in accordance with the relevant Australian and International Standards.

Clevertronics Pty Ltd is a vendor of CleverEVAC products. It is not a fire engineer or designer. It does not purport to recommend its products for use in any particular application or to achieve any particular outcome.

Purchasers and users of its products must take their own steps to ensure compliance with statutory requirements, safe practice and suitable application of the products

Installation:

The L10 UltraBlade Pro Dynamic Red is a recessed ceiling mount fitting. The UltraBlade Pro Dynamic Red can be attached directly to any solid surface, or to a ceiling tile. The Fitting comes with an attached Flex and Plug. Please follow the steps below to install the Exit:

- Create a cut-out (350mm x 70mm) in the mounting surface.
- Remove the Fire Panel Input terminal block by disengaging the clip. Refer to Image below.
- Route the power cord to the mains connection and connect the 240VAC supply.
- Route 24V/VF control cables through the access hole and connect to the terminal block as per next step.
- Connect positive signal of RED activation to I2 and negative signal to C (Common).
- Connect positive signal of GREEN activation to I1 and negative signal to C (Common).
- Reinstall the terminal block.
- Insert the Fitting into the ceiling cavity tighten the (4) clamping screws.
- Alternately, fix the Fitting to a solid surface using (4) screws through the surface material.
- Install the cover plate, Apply power to the fitting and test.
- To disable the Dynamic Green mode coming on in Emergency mode Set dipswitch 1 to OFF position.

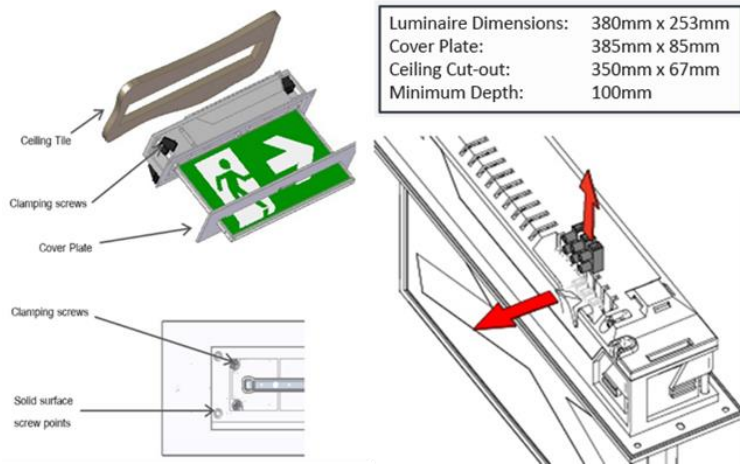

NOTE: For the Dip Switch setting to take effect the power and battery will need to be disconnected and reconnected.

Dynamic Red 24 Volt (24V)/Volt Free (VF) Operation and Testing

Activation of the Dynamic Red/Green is controlled via 24V/VF control interface. The fitting comes pre-set as normally OFF. This is switched via an intelligent circuit inside the fitting. This is controlled by the 24V/VF input from a fire panel or other source. If you would like to change the activation of the Dynamic Red/Green from Normally OFF to Normally ON change the Dip Switch no.2 (RED)/ no.3 (GREEN) found next to the fire Panel Input terminal block

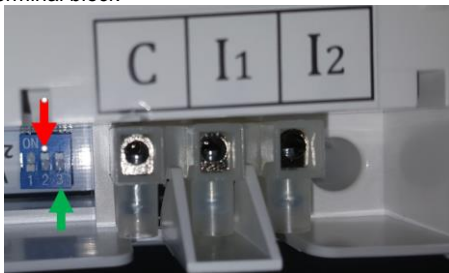

Selecting the Type of the Interface

The fitting comes pre-set to the Volt Free(VF) control interface, to change this to 24V you will have to change the switch from VF to 24V found next to Fire Panel Input Terminal Block. Please see image below.

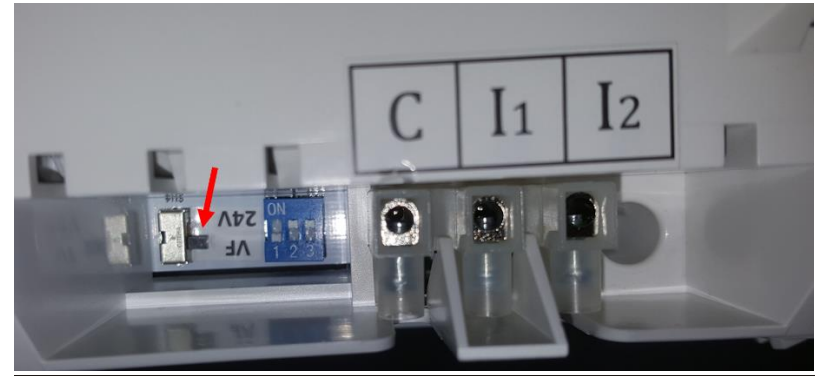

Zoneworks, HIVE (HV/HVG) and DATA Monitored Options

Luminaires with part numbers having -ZW, -HV, -HVG, -DATA are fitted with Zoneworks communications modules (nodes). These fittings are monitored using either Powerline Carrier Technology that utilises the power cable to provide data communication or a dedicated data cable to/from data routers installed on a dedicated data trunk connected to a central Server (can also be connected via Ethernet/Internet/Fibre). Zoneworks software on the server is used to monitor, coordinate testing and collate test data from each fitting and can be commissioned by scanning of the supplied barcode. The LED Test Switch indicator provides a multifunction indication of the status of the luminaire during testing and normal operation:

Option	State	LED Operation
ZW, HV, HVG, DATA	Commissioned	LED on Solid (Green)
ZW, DATA	Un-commissioned	Batt plugged-in: Amber 1s, green 1s
		Batt unplugged: red 1s, off 1s
HV, HVG	Un-commissioned With network connectivity	Batt plugged-in: Amber 1s, green 1s
		Batt unplugged: red 1s, off 1s
HV, HVG	Un-commissioned Without network connectivity	Batt plugged-in: Amber 250mS, green 250mS, Amber 250mS, green 250mS, green 1s
		Batt unplugged: red 250mS, off 250mS, red 250mS, off 250mS, off 1s
ZW, DATA	Emergency Light Test In Progress	LED flashes at Amber 5s ,Off 1s
HV, HVG	Emergency Light Test In Progress	LED flashes at Amber 1s , Off 1s

In the case of the DATA version a 2-way "figure 8" cable and terminal block facilitates the connection to the DATA network via a multi-drop bus (daisy chain connection). For further information of installation of a Zoneworks system, please refer to the Zoneworks Users Guide and Commissioning Guide (incl. DATA version)

Caution:

On many building sites, power circuits may be cut off in an uncontrolled and repetitive basis during construction. As a result, any Exit & Emergency Units, on these circuits, will have their batteries discharged or "cycled". The Li-ion battery in this fitting has been selected to give excellent long life performance in a controlled AS/NZS 60598.2.22 testing environment. Excessive battery cycling will reduce through-life performance and may lead to premature battery failure. Battery warranty claims, as a result of such abuse, are specifically EXCLUDED from Clevertronics warranty terms.